

*FIIF Industrial Automation Day 2026*

# Data Contextualization for AI with OPC UA

Jouni Aro  
CTO, Prosys OPC  
7.5.2026



# Agenda

**1**

Intro

**2**

OPC UA

**3**

Information  
Models

**4**

AI with  
OPC UA

# Proslys OPC



- Founded in 1995
- Global expert in
  - OPC UA solutions and information modeling
  - IT/OT integration
  - Industrial Security
- An active member of the OPC Foundation and Open Industry 4.0 Alliance



- 50+ countries
- 1000+ customers

# Our Product Family

## Developer Tools



OPC UA  
**SDK for Java**



**Sentrol**  
OPC UA & Classic  
**SDK for Delphi**



QuickStart



Solution  
Development



Consulting



Workshops

## Integration & Visualization



OPC UA  
**Forge**



OPC UA  
**Monitor**

## Simulation & Testing



OPC UA  
**Simulation Server**



OPC UA  
**Browser**

# Build with Prosys Forge

- Industrial DataOps & Edge Application
- OPC UA Server as the core
- Variety of south- and northbound connectivity
- Business logic tools
- Comprehensive security features
- Windows, Linux, Container
- Web configurator
- OpenAPI REST API

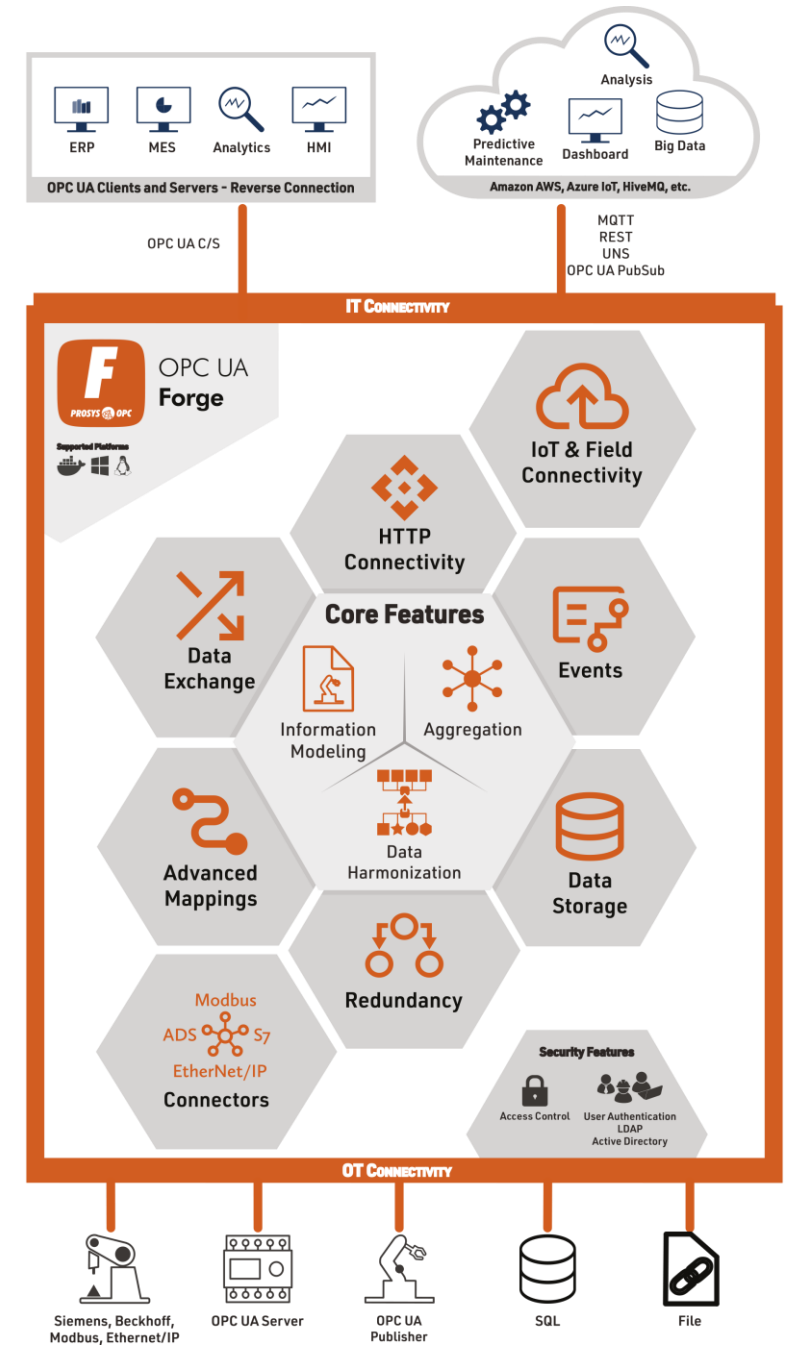



**OPC UA**

# OPC UA Enabled Architecture

- OPC UA Client/Server (C/S)
  - Process Monitoring
  - Production Control (SCADA)
  - Production Orchestration (MES)
- OPC UA PubSub UDP
  - Field Level Communication
  - Field Exchange (OPC UA FX)
- OPC UA PubSub MQTT
  - Cloud Connectivity
  - Cloud Exchange (OPC UA CX)
  - Unified Namespace (UNS)

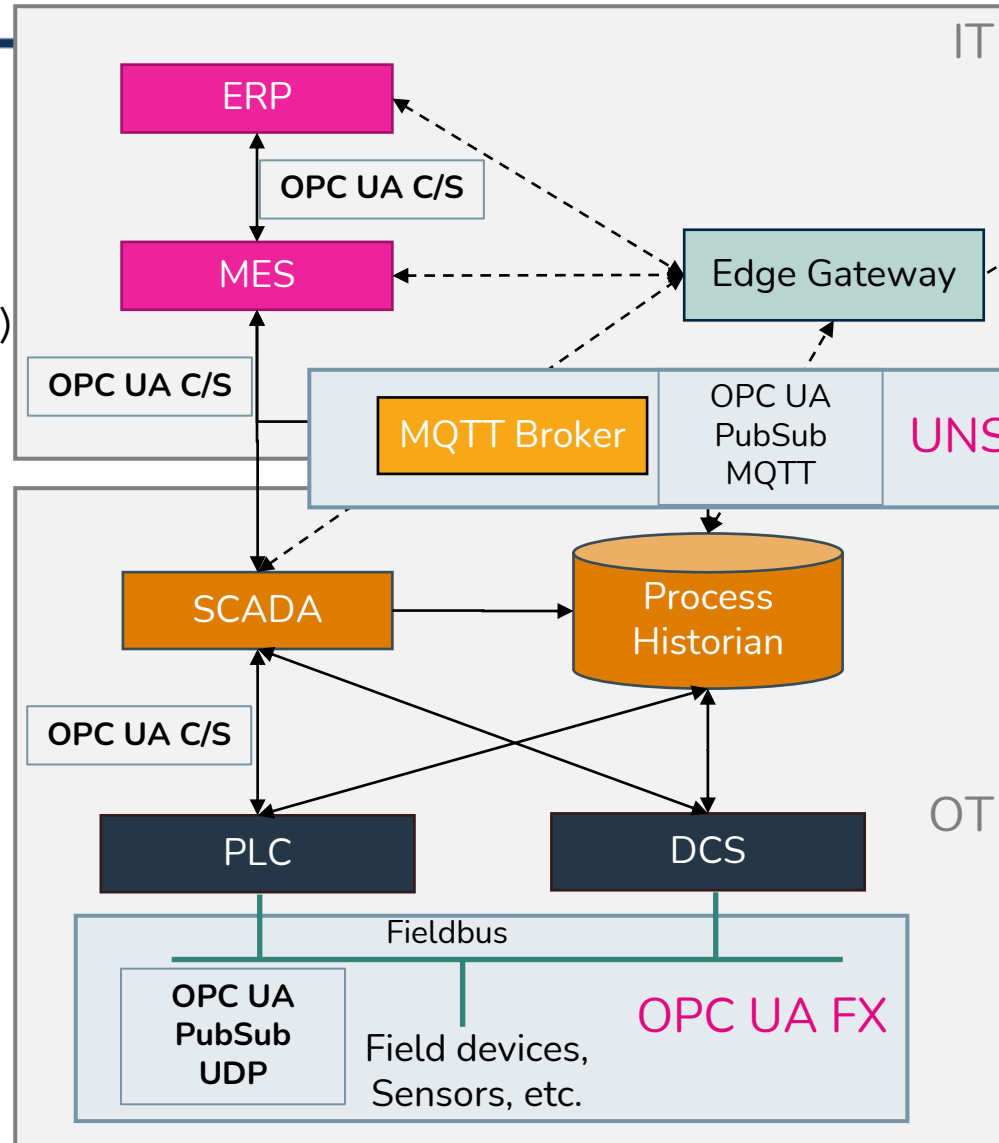

ERP = Enterprise Resource Planning  
 MES = Manufacturing Execution System  
 SCADA = Supervisory Control And Data Acquisition  
 PLC = Programmable Logic Controller  
 DCS = Distributed Control System

# OPC Unified Architecture

---

- OPC UA is a global standard for Industrial Connectivity
  - OPC Foundation as a standardization body
  - Protocols available for Field Level, Industrial IT Level, and OT to Cloud Level communication
- OPC UA main benefits
  - Cross-vendor compatibility at the system level
  - Security built in
  - Large adoption among automation and industrial IT vendors
- Information modeling
  - Generic modeling language
  - Domain specific models via wide collaboration
  - Custom models



# Information Models

# Brownfield Device Control

- Process/Machine Control
  - PLC
  - SCADA
  - DCS
- Data Model
  - Tags
- OPC UA Server
  - Tags
- Is that it?

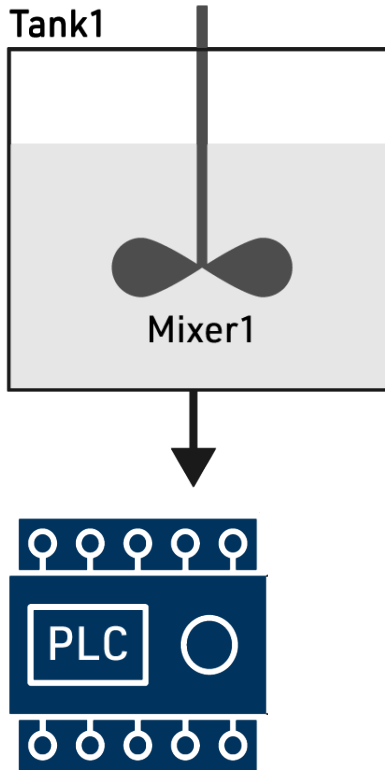

OPC UA Server

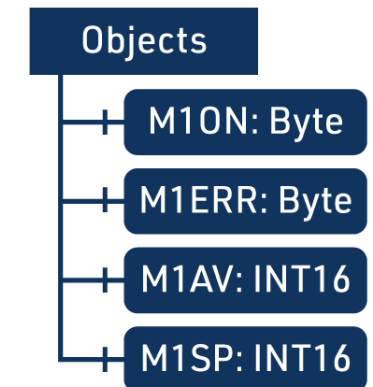

# Better Semantics with OPC UA

- Variables
  - Standard DataTypes
    - Boolean, Int32, Double, etc.
  - Custom DataTypes
    - Structures
    - Enumerations
- Object
  - Device Structure
- ObjectType



# Additional Semantics with OPC UA

- Method Calls
- Events
- Alarms
- History
- State Machines

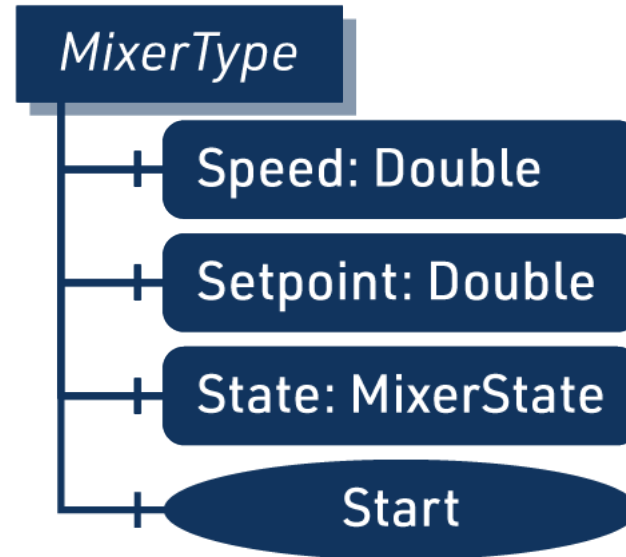

# Information Models

- Domain specific models
  - Devices
  - Machinery
  - Robots
  - Process Automation (PA-DIM)
  - Etc.
- Custom models
  - Vendor specific
  - User specific

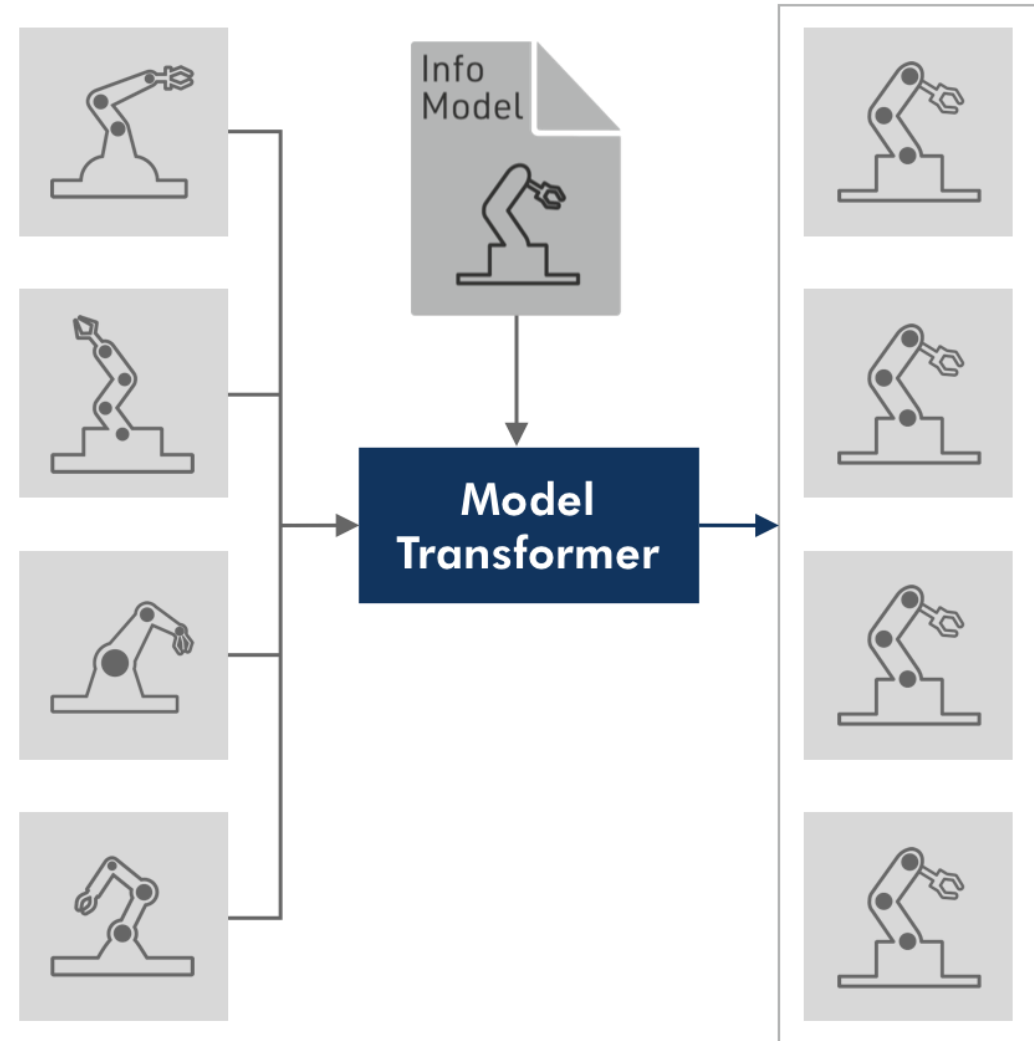

# AI with OPC UA



# AI as an Enabler

---

1. Information Model Exploration
  - Standard models enable better understanding
  - Model Context Protocol (MCP) enables AI chat interface
2. Time-Series Analysis
  - Forecasting
  - Anomaly Detection
3. Mapping Legacy Data to Standard Information
  - Laborious mappings made possible
  - Balance between automatic and manual verification

# Information Model Exploration

---

- Model Context Protocol on Prosys Forge
  - Based on efficient indexing of address space data
- Ask questions about production state and data
- Claude even created a report without specifically asking for it
  - Find the correct variable from the Forge address space
  - Understand what the measurement is, based on the Laboratory and Analytical Device Standard (LADS) information model
  - Find out that it has history available
  - Generate a report with proper meta data (what and where it is) about the measurement

I'll search for a pH measurement node on the server.

GetNodes >

Found the pH Sensor (node `i=5019`) under the LADS pH-Meter. Its `SensorValue` (node `i=6113`) is the measured pH — and it has `HasHistoricalConfiguration`, so history is recorded. Let me also grab the engineering units/range and then pull 10 seconds of history.

Read >

Confirmed — current pH = 4.19, range 0-14 pH. Server clock is at 13:44:34 UTC. Let me pull the last 10 seconds of raw history.

HistoryReadRaw >

Got 10 samples, all reading exactly 4.19 pH (a stable acidic reading — makes sense for a sample that's settled on the sensor). Let me build a lab-themed chart artifact.

Created a file, read a file >

Found it — your pH measurement is the `SensorValue` of the pH Sensor inside the LADS pH-Meter:

#### Node

- Display name: `pH Sensor / SensorValue`
- NodeId: `nsu=.../pHMeter/;i=6113`
- Engineering unit: `pH` (potential of hydrogen), range `0-14`, history enabled
- Path: `pH-Meter → Functional Unit Set → pH-Meter Unit → FunctionSet → pH Sensor → SensorValue`

#### Readout for the last 10 seconds (13:44:24 → 13:44:34 UTC)

- 10 samples, all returning pH 4.19 —  at line. The sensor is sitting on a stable, mildly acidic sample (think vinegar or tomato juice territory; well

Reply...



Opus 4.7



LABORATORY · SPECTARIS PH-METER · LADS

INSTRUMENT LADS-SampleServer

*Potential of Hydrogen*

SCALE 0.00 — 14.00 pH

SAMPLED 2026-04-22 · 13:44

Node: `i=6113` · `SensorValue` · recorded window:  
10.00 s

UTC

#### LATEST READING

4.19 pH

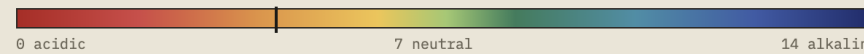

#### WINDOW STATISTICS

Samples	10
Duration	9.10 s
Mean	4.190 pH
Min / Max	4.19 / 4.19
Std dev	0.0000
Classification	ACIDIC

#### SAMPLE LOG

T (s)	PH
+0.00	4.19
+1.09	4.19
+1.30	4.19
+3.17	4.19
+4.08	4.19
+5.01	4.19
+6.10	4.19
+6.31	4.19
+8.19	4.19
+9.10	4.19

# Time-Series Forecasting

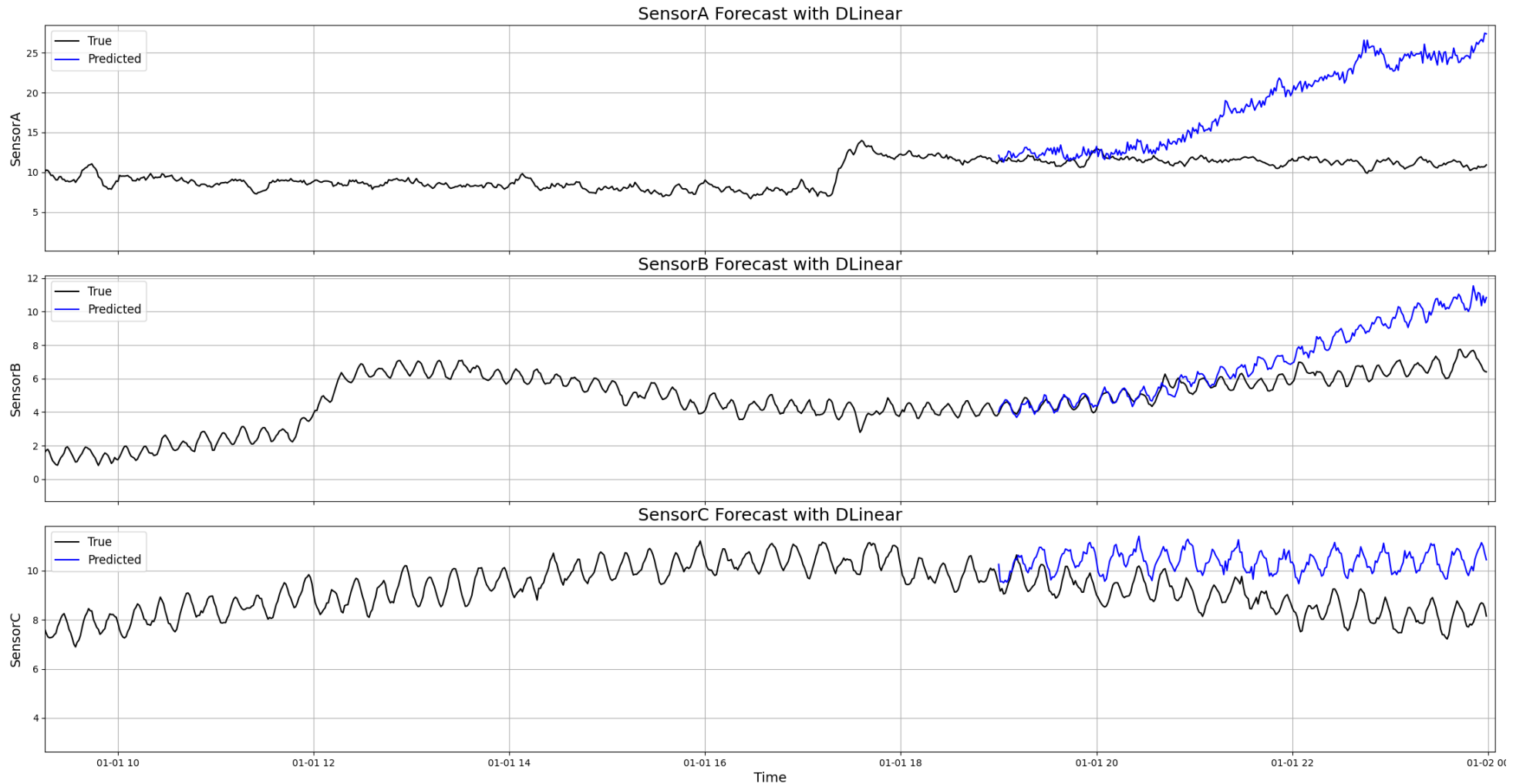

# Time-Series Anomaly Detection

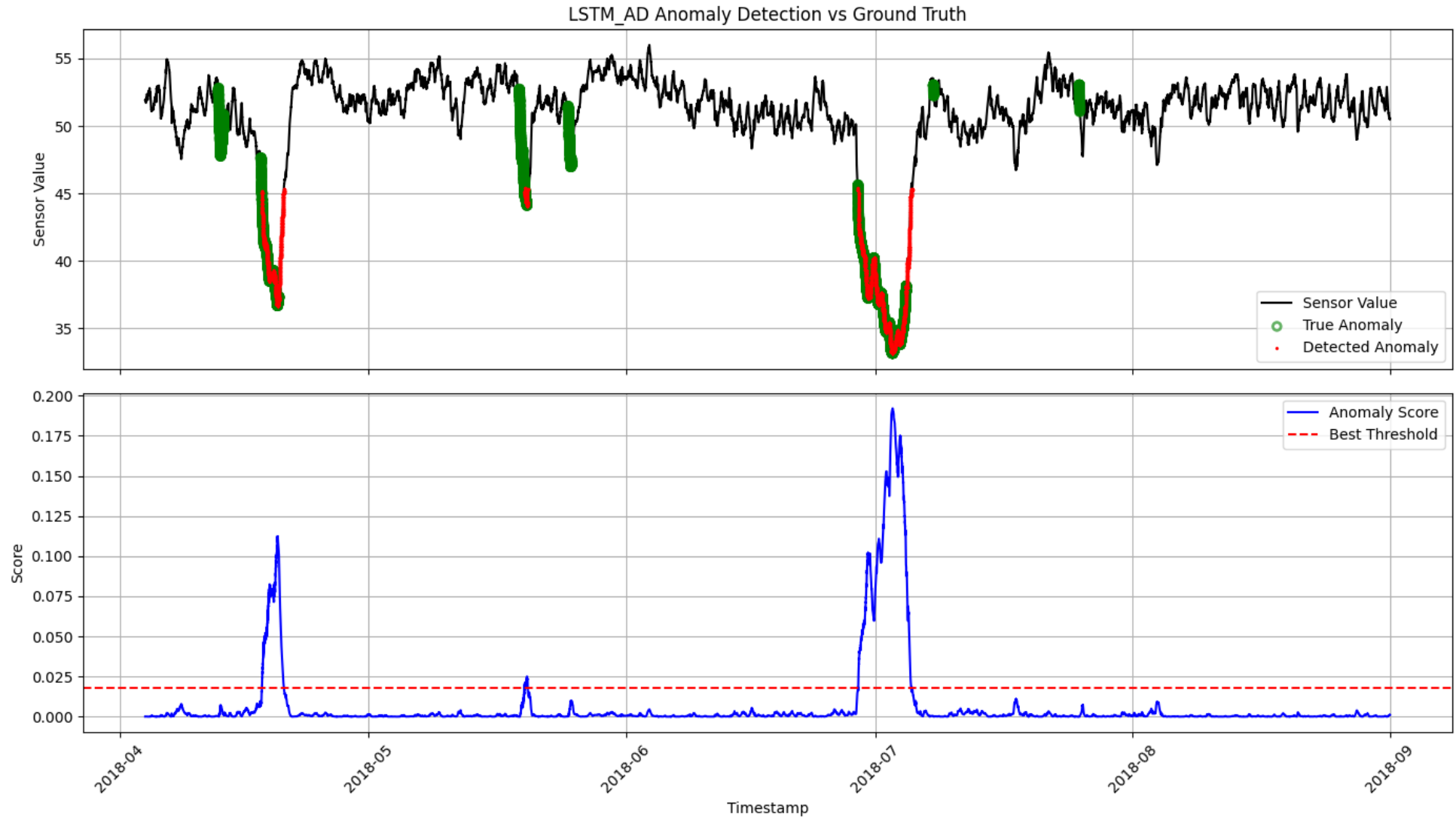

# AI-assisted Mapping

- Enable model transformations
  - Large models
  - Acceptable work time
- Confidence-based evaluation:
  - Automatic mapping
  - Manual verification
  - Rejected without review

(Tuomas Kauppinen: AI-Assisted Variable Mapping to OPC UA Information Models, MSc Thesis, Tampere University, 2026 (upcoming))

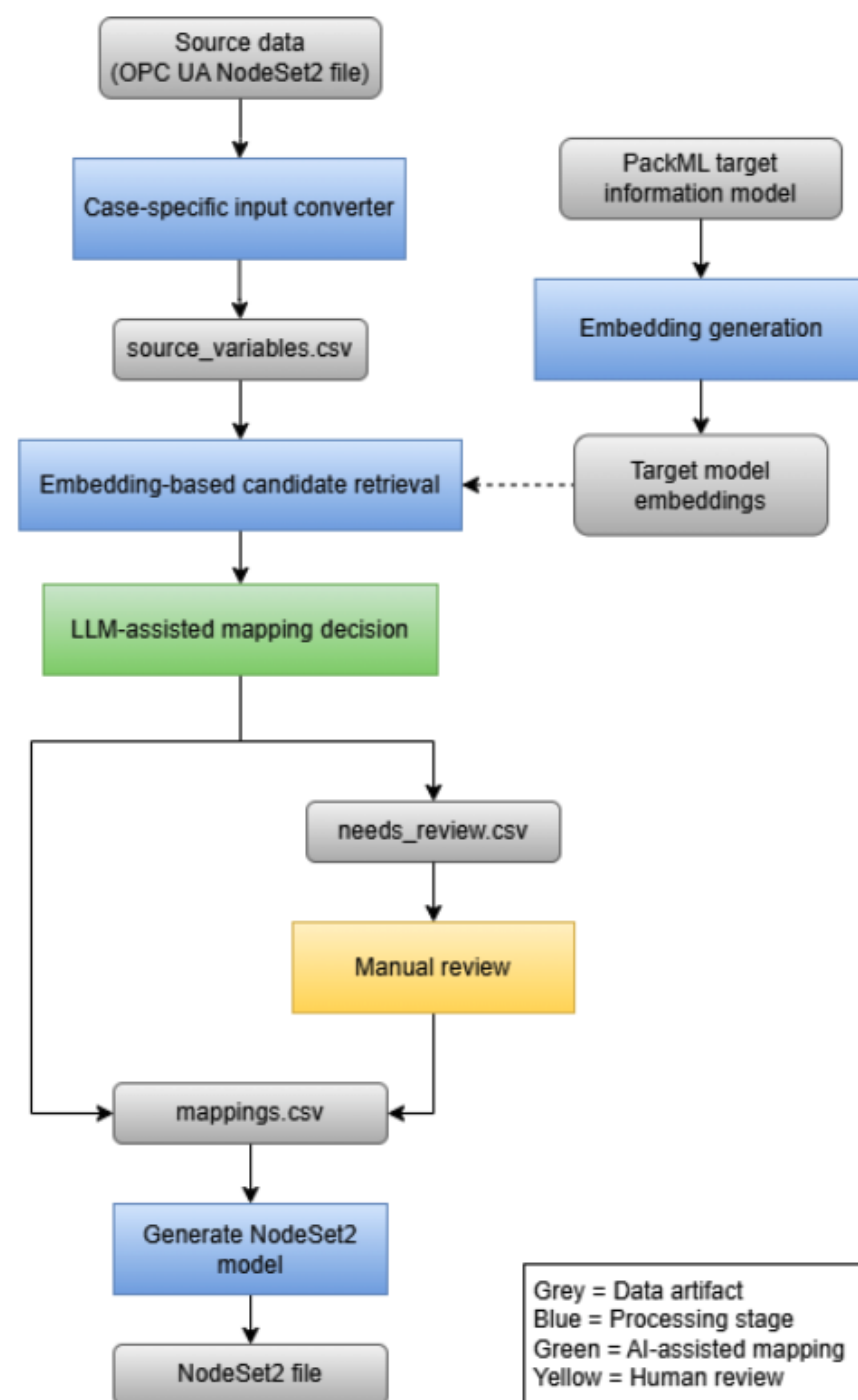



# Conclusion

# Data Contextualization for AI with OPC UA

---

- OPC UA Enables
  - Data Aggregation from different sources
  - Data Contextualization to information models
- AI Enables
  - Chat-based queries
  - Time-series analysis
  - Legacy data mapping

# Thank You!

Please contact us for more information.



[jouni.aro@prosysopc.com](mailto:jouni.aro@prosysopc.com)



OPC UA  
**Forge**



OPC UA  
**Simulation Server**



OPC UA  
**Forge Plugin**



OPC UA  
**Browser**